

www.e-quality-eu.org

TUNIV approach to knowledge-based learning material design

Bartłomiej Małachowski
Szczecin University of Technology



Experience-based Quality in European ODL
E-QUALITY



**FINAL SEMINAR 21.-22.9.2006
SZCZECIN, POLAND**



Didactical material creation

Knowledge-flow-diagram

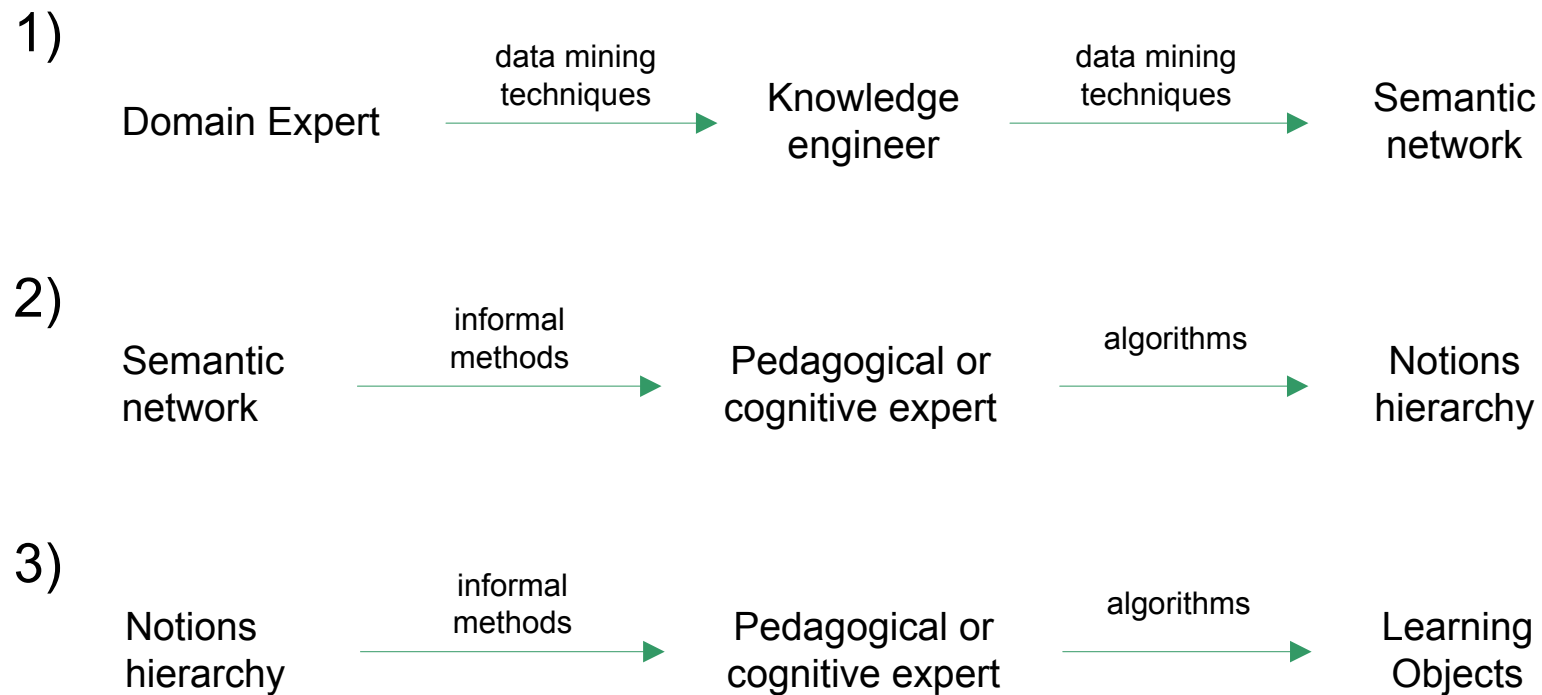



Experience-based Quality in European ODL

E-QUALITY

Didactic material structure definition

Title: Planning and Simulation of Manufacturing Processes

I. Semantic analysis of the title

Notions: [*planning, simulation, manufacturing processes*]

II. Notions depth analysis

planning: [*strategic, tactical, operational*]

simulation: [*discrete, continuous, dynamic, static*]

manufacturing
processes: [*discrete, continuous*]



Education and Culture

Socrates





Notions depth analysis

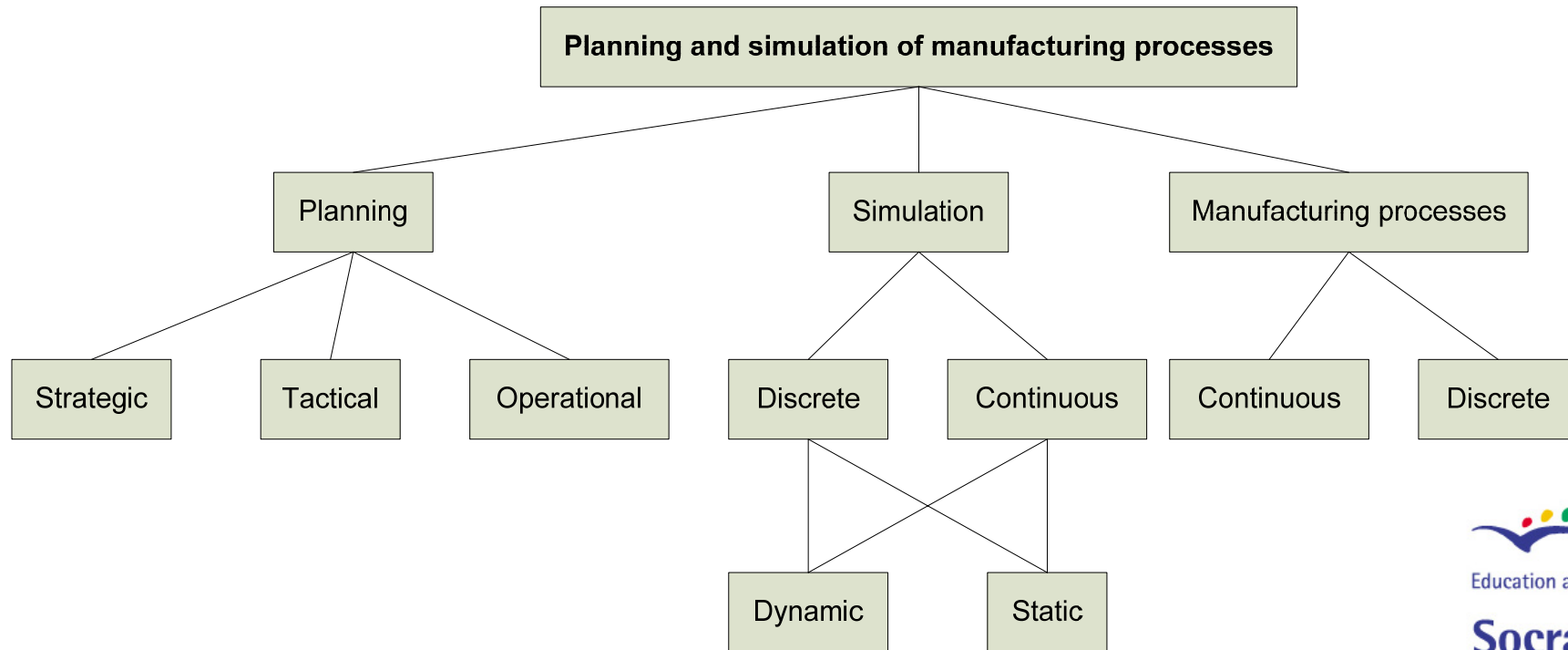



Didactic material size analysis

III. Material scope analysis

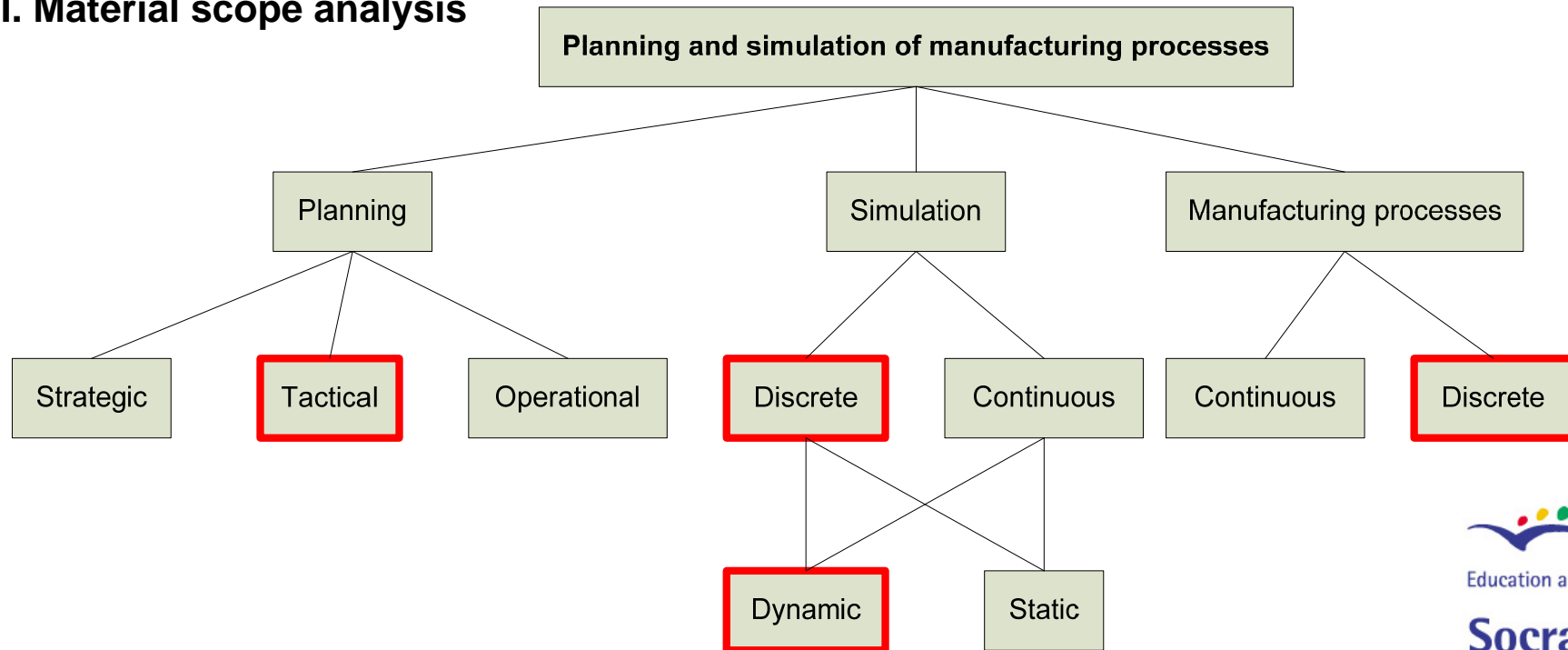

Analysis result: Tactical planning and discrete, dynamic simulation of the discrete manufacturing processes



Experience-based Quality in European ODL

E-QUALITY

Methodology of teaching a material of given size

Planning and Simulation of Manufacturing Processes

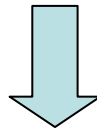

Tactical planning and discrete, dynamic simulation of the discrete manufacturing processes

Fundamental knowledge (<i>what?</i>):	10%		40%
Procedural knowledge (<i>how?</i>):	40%	or	30%
Project (<i>where?</i>):	50%		30%



Socrates





Simulation semantic network

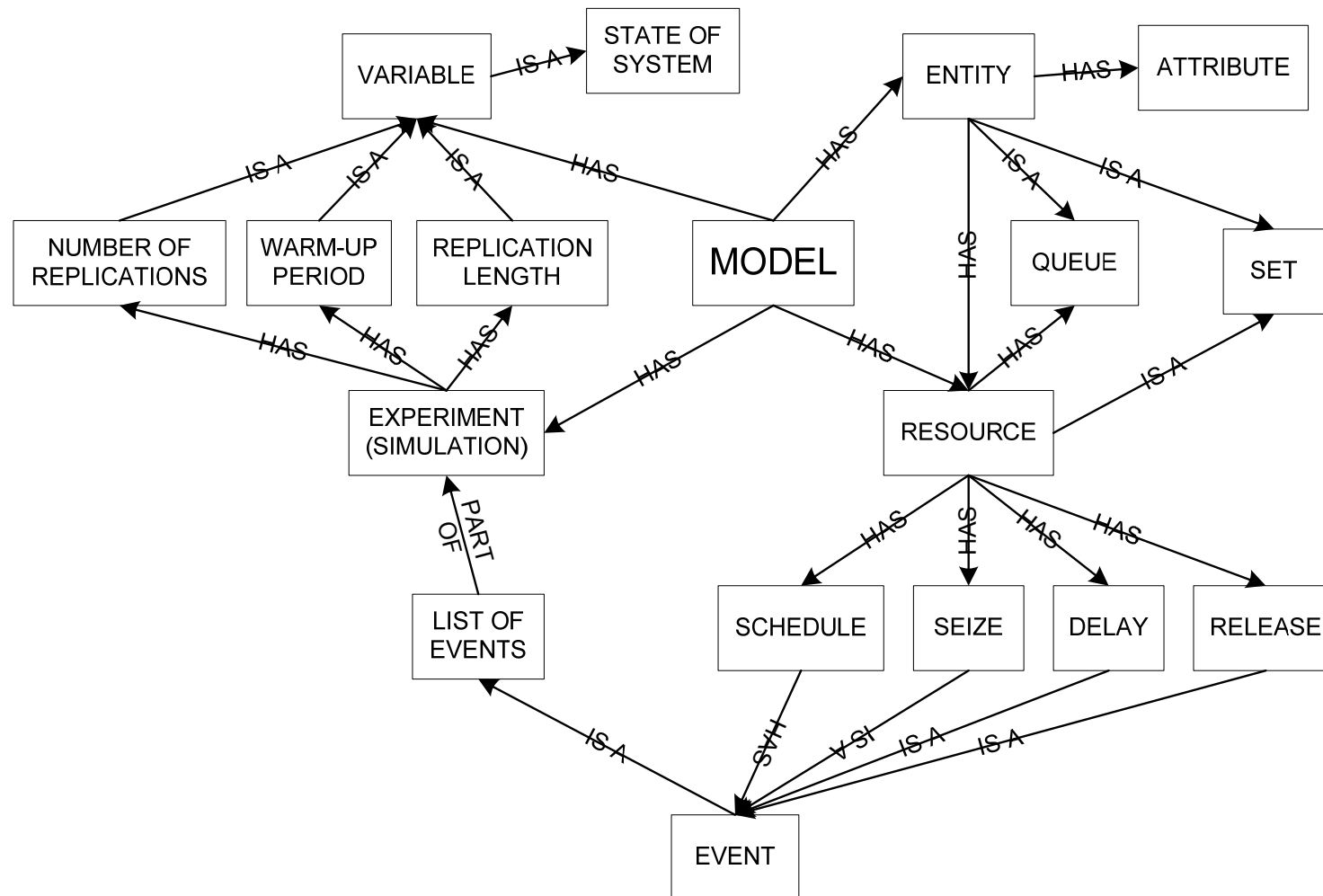



Simulation semantic network

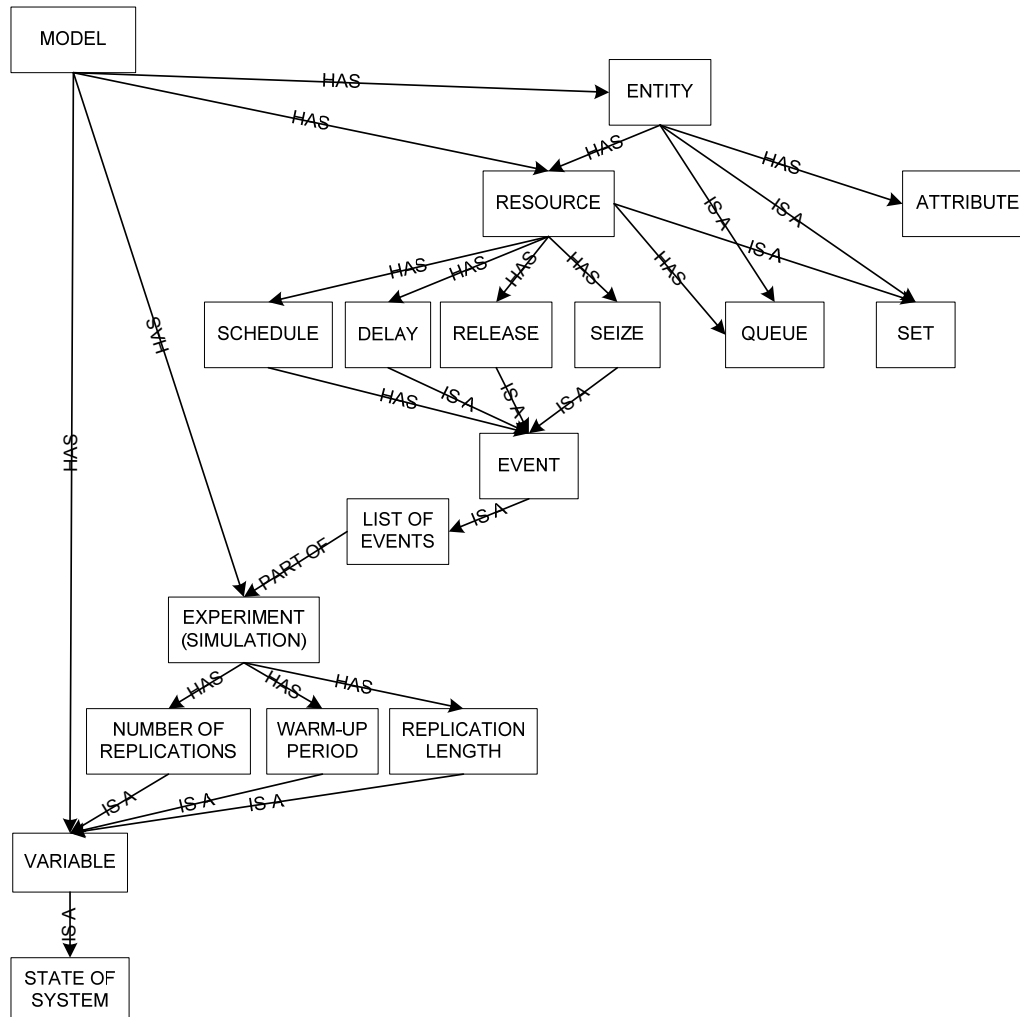



Queuing systems hierarchy

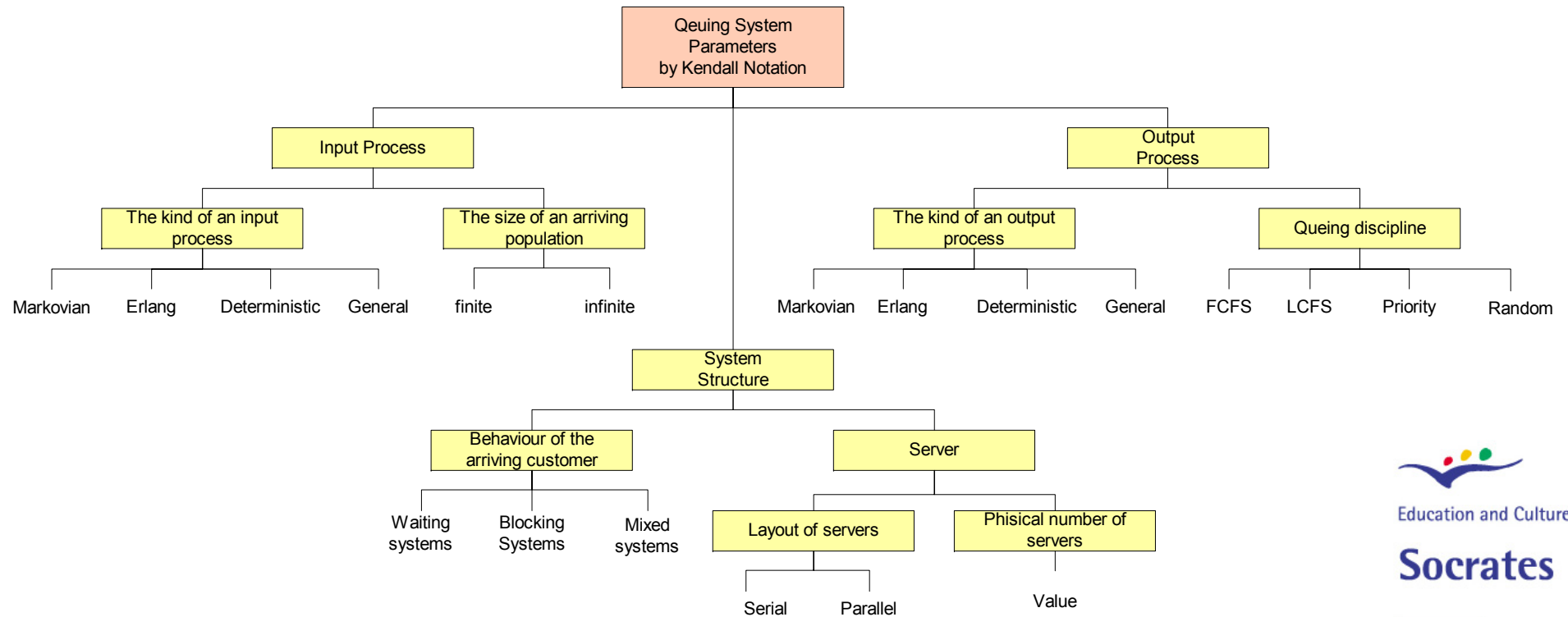



Simulation hierarchy

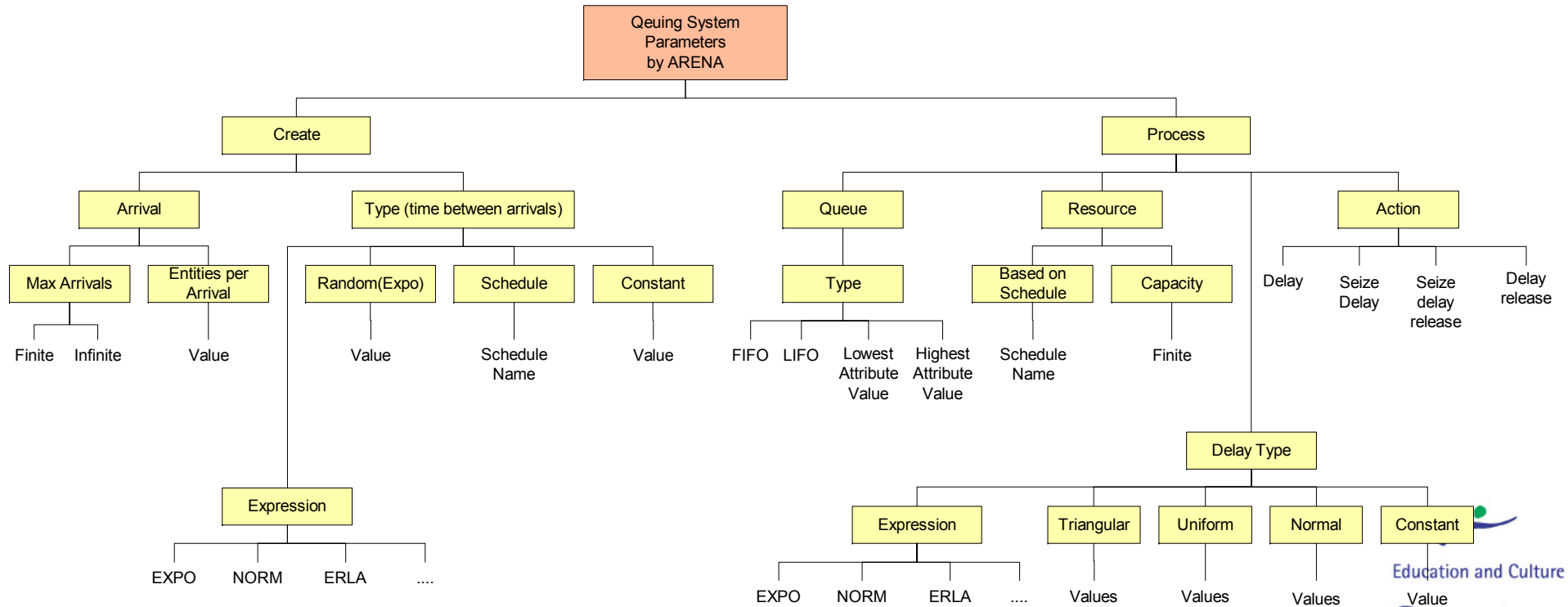



Concepts mapping

